

CHUNK BAR

1200mm & 1800mm Bar Tables



scan me

PARTS:

TOP (A) 1pc	LEGS (B) 2pc	FOOTRAIL (C) 1pc
TOP (D) 2pc		
HEX HEAD (E) 2pc	M6 SPLIT WASHER (F) 2pc	DOWEL (G) 4pc
SELF TAPPING BOLTS (H) 8pc	M8 SPLIT WASHER (I) 8pc	
WASHER (J) 8pc	BRACES (K) 4pc	PHILLIPS HEAD (L) 38-44pc

TOOLS (NOT INCLUDED):

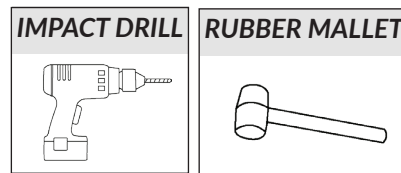

We strongly recommend using an impact drill with a 4mm hex, a 13mm socket and a long phillips head drill piece. Scan the QR code with a phone or tablet to access the assembly video.

WARNING:

Make sure the frame is flush to the top before screwing in the phillips head screws.

INSTRUCTIONS:

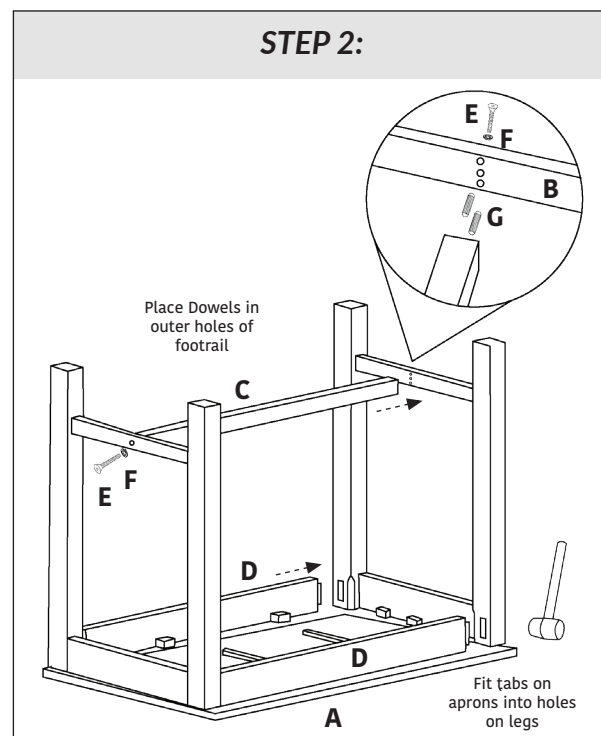
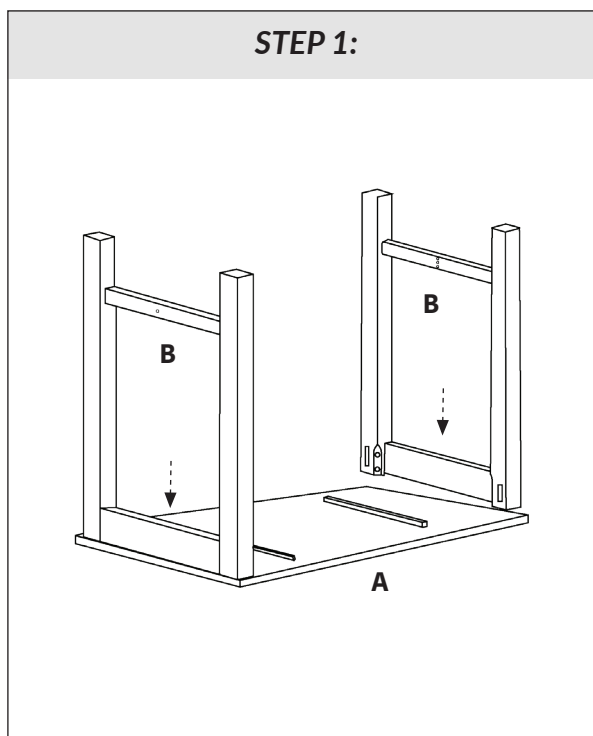

CHUNK BAR

1200mm & 1800mm Bar Tables



scan me

STEP 3:

Before screwing into the top, make sure frame is aligned flush

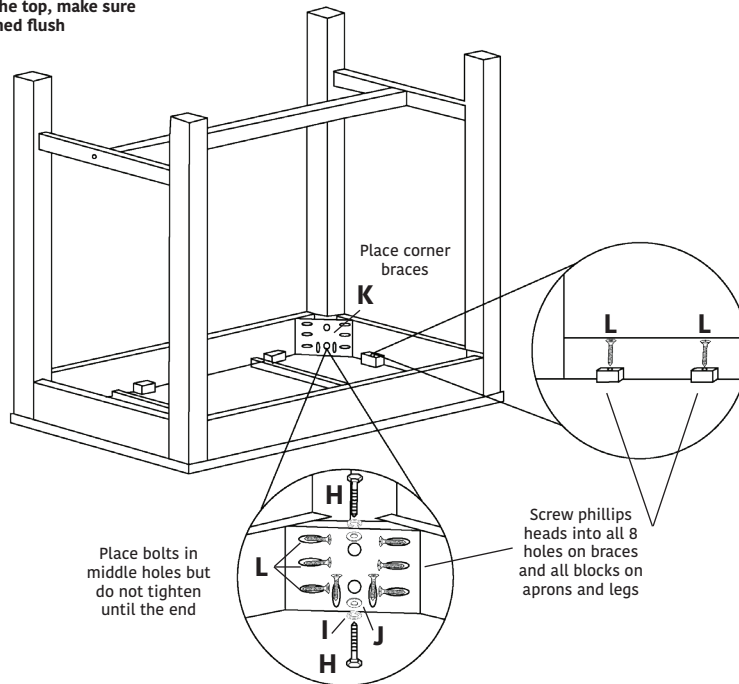

COMPLETE:

